



YANMAR

SV100-2PB

MIDI-EXCAVATOR



Operating weight

10 360 kg

Engine

Yanmar 4TNV98CT-VBV with DPF

Net power

51,7 kW (70,3 HP) at 2100 rpm

Digging force (arm)

45,8 kN / 40,9 kN

Breakout force (bucket)

68,5 kN

A GAME CHANGER IN ULTRA-TIGHT TURNING EXCAVATORS





COMPACT DESIGN

Designed to perform in even the tightest worksites, toughest conditions and most challenging terrains, the SV100-2PB sets the standards in performance and capability. With the compact dimensions of a midi-excavator but delivering the stability and power of a much larger model, the 10-tonne machine has a width of just 2,320mm. Perfect for a wide range of applications, the SV100-2PB is the ideal choice for urban renewal and grading.



SIMPLE OPERATION

Thanks to ergonomic cab design, control levers are perfectly positioned for easy and precise operation. Major commands can be delivered via the joysticks, meaning maximum comfort and productivity for the operator.



STATE-OF-THE-ART ENGINE

Adopting Yanmar's 4TNV98CT 4-cylinder turbocharged diesel engine and featuring cooled EGR and DPF as standard, the SV100-2PB is fuel efficient, environmentally friendly and fully-compliant with EU Stage V emissions legislation. Direct injection and common rail technology maximise engine performance, while auto-idle (available as an option) provides ultimate control for the operator.



SETTING THE STANDARDS IN SAFETY

Achieving ROPS, TOPS and FOPS level I certification (for both the canopy and cabin), the SV100-2PB sets the standards in on-site safety. With an orange seatbelt and LED work lights fitted as standard, operators can specify optional FOPS level II protection and an LED beacon for maximum protection.



UNIQUE ARTICULATED BOOM

The SV100-2PB features a completely unique articulated boom and achieves class-leading performance in lifting, moving and placing loads. This not only improves manoeuvrability, but also enhances operator precision.



COMFORTABLE CAB

Adopting Yanmar's 'Universal Design' concept, the SV100-2PB boasts the widest cabin in its class and increased legroom. A refreshed operator station, new instrumentation, seat with air suspension and rearview camera (included as standard).



INNOVATIVE HYDRAULICS SYSTEM

Powered by Yanmar's globally-acclaimed ViPPS hydraulic system, which cumulates the flow of separate pumps to deliver the perfect combination of speed, power, smoothness and balance, the SV100-2PB enables simultaneous operation of working movements – even while traveling.



LOW TOTAL COST OF OWNERSHIP

Fuel efficient, easy to maintain and guaranteeing a long service life, the SV100-2PB has been designed to achieve a low total cost of ownership.

POWER, PRODUCTIVE AND COMPACT

The perfect combination of technology and innovation, the SV100-2PB delivers outstanding performance while offering the benefits of a compact excavator. Perfect for a wide variety of applications, it combines power and versatility with comfort and reliability.

UNMATCHED STABILITY

Featuring Yanmar's VICTAS® system, which increases the support surface and tracking through asymmetric crawlers, the SV100-2PB leads the way in stability and manoeuvrability. Additional benefits of the system include reduced track degradation, quieter displacements and reduced vibration.

Thanks to a large counterweight and excellent weight distribution, the SV100-2PB achieves greater stability than conventional machines of similar weights, while delivering exceptional lifting, and digging performance.



2-PIECE ARTICULATED BOOM

The SV100-2PB features a single top-mounted articulation cylinder, which offers several advantages for the operator:

- + Total protection of the cylinder rod against damages
- + A 50% reduction in dead weight (which dramatically improves stability)
- + Reduced daily maintenance/TCO costs
- + Compact boom design, with fewer components, for class-leading visibility

ERGONOMIC DESIGN

With operator comfort prioritised throughout the design process, the boom articulation is operated via the left control pedal. This enables the simultaneous use of boom and work attachments (via the joysticks).

UNIQUE FUNCTIONALITY

Operating at high working pressure, the SV100-2PB offers outstanding break-out force. The boom articulation cylinder has been reverted to accelerate the boom lift movement, while slowing down the lowering movement - essential for the accurate positioning of loads.



FLEXIBLE, ACCURATE AND VERSATILE

The SV100-2PB is equipped, as standard, with two auxiliary circuits – proportional control on the joystick and adjustment of the oilflow by potentiometers enable fine adjustment. This allows operators to adapt the flow of oil to match the requirements of each attachment, providing perfect control for every task.



- 1 Right joystick: proportional control of the first auxiliary circuit (hammer).
- 2 Left joystick: proportional control of the second auxiliary circuit (grapples, rotation).
- 3 Button at the bottom of the right joystick and red light indicates the constant flow.
- 4 Two potentiometers to adjust the oil flow.

UNPARALLELED PERFORMANCE

Thanks to unmatched industry expertise, all Yanmar excavators deliver exceptional performance, while ensuring minimal environmental impact. The SV100-2PB is flexible, powerful, productive and precise – the perfect partner for excavating, grading, demolition and backfilling.



POWERFUL VIPPS HYDRAULIC CIRCUIT

Featuring a hydraulic circuit with aggregated power regulation, the SV100-2PB is equipped with a double piston pump with variable flow, gear pump and multiple combination directional control valve.

Pumps engage automatically, depending on the operation being performed, to ensure ease of use for the operator. The pump flows not only increase productivity, but also allow smooth and simultaneous use of equipment – even when travelling.

Thanks to the addition of an all-new electronic hydraulic pump regulator, which adjusts its flow rate depending on engine performance, power can be fully exploited and machine performance can be effectively optimised.

POWER AND PRODUCTIVITY



The perfect combination of power and precision, the SV100-2PB adopts next-generation technology to maximise performance and minimise environmental impact. Designed with the operator firmly in mind, it delivers the performance and versatility to excel in every application.

YANMAR STAGE V ENGINE TECHNOLOGY

The SV100-2PB adopts Yanmar's next-generation 4TNV98CT engine platform. The result of significant progress in low-carbon vehicle operation, it meets Stage V emissions regulation thanks to cooled exhaust gas recirculation (EGR) technology and the addition of a diesel particulate filter (DPF) as standard.

To further improve efficiencies, the excavator features Yanmar's exclusive regeneration system to prevent clogging and cleaning downtime.

MAX POWER

With a displacement of 3,318 cm³, the SV100-2PB delivers 53.7 kW and 283 Nm torque at 1,365 rpm. Alongside guaranteeing exceptional lifting and carrying performance, this also minimises noise emissions.

MAXIMUM EFFICIENCY, MINIMUM EMISSIONS

- + The ECU manages RPM according to torque demand, which optimises engine load, reduces fuel consumption and improves productivity.
- + When cycles require low power and movement, Yanmar's Eco Mode controls the engine speed to reduce operating costs.
- + Auto-idle technology sees the engine switch to idle if operating levers are left untouched for more than four seconds. This reduces fuel consumption and limits wear.

UNBEATABLE RELIABILITY



Designed to maximise reliability, durability and dependability, the SV100-2PB adopts a number of features to ensure operators can deliver even the most demanding tasks. For example, the structure of the undercarriage (and use of steel covers) prevents total protection of the chassis. What's more, hoses are protected with abrasion-resistant sleeves, while their routing on the top of the boom prevents the risk of torsion.

The blade and boom cylinders are also protected by steel plates, while steel parts have undergone cathodolysis treatment to ensure maximum protection against paint corrosion. Finally, form stringers prevent the accumulation of soil, while simultaneously reducing internal track wear.

STATE-OF-THE-ART DIGITAL INTERFACE

To provide the operator with real-time machine data, the SV100-2PB is equipped with a state-of-the-art digital interface. Seamlessly integrated into the right-hand console, the 3.3" screen provides excellent visibility – even in bright sunlight or at night.

Providing valuable operational information, the interface allows you to track working time and daily maintenance, as well as real-time data – such as engine oil, coolant temperatures and fuel level. It also warns the operator in case of machine errors (low battery charge, abnormal oil pressure, clogged air filter, etc.).



MAXIMUM COMFORT

Thanks to clever design and intricate attention to detail, the cab of the SV100-2PB is large, spacious and comfortable – perfect for those long days spent on site. Operators benefit from class-leading visibility, as well as ergonomic design, which ensures maximum productivity.

SPACIOUS CABIN

A well-designed interior, including large legroom, allows the operator to comfortably work for long periods of time. Access to the cab is wide, making entry and exit easy.

SEAT WITH AIR SUSPENSION

The SV100-2PB is fitted with a wide seat, featuring air suspension and headrest as standard. The seat is fully-adjustable, which makes finding the perfect operating position quick and easy.

ADJUSTABLE AIR CONDITIONING

Improved air conditioning, alongside cleverly placed vents, allow the operator to maintain a comfortable temperature within the cab. The air conditioning filter is positioned within the cab itself, which ensures easy maintenance, while a defrost function provides quick and easy demisting of the windscreen.

- + Radio with USB port
- + Numerous storage spaces and bottle holder
- + Air conditioning filter
- + Automatic ceiling light
- + Two 12-volt socket
- + Toolbox



EASE OF USE



INTELLIGENT ERGONOMICS

The architecture of the SV100-2PB cab aims to improve operator comfort and maximise productivity. Alongside adjustable wrist supports, wide travel pedals and smooth hydraulic control levers ensure exceptional precision and ease of use.

AUTOMATIC SECOND SPEED

The SV100-2PB has an automatic second speed for long displacements, while a power switch keeps the machine in first gear when tackling challenging terrains or uneven ground.

360° VISIBILITY

Thanks to large windows and clever hood design, operators benefit from excellent visibility. The front windshield, divided into two parts, is fully retractable and the windows on the right-side slide, allowing the operator to easily communicate with other workers.

This 360° visibility ensures optimum safety on site and improves operator efficiency. It also reduces the risk of damaging the machine, especially in tight spaces or congested job sites.

UNBEATABLE VISIBILITY DURING LOADING

The front part of the roof is transparent, which provides unbeatable visibility during loading or demolition operations and enables total control.

PANORAMIC CONTROL

With five rear and side mirrors, the operator has complete visibility of the work area and the area around the machine - all without having to move from his seat.



SETTING THE SAFETY STANDARDS



Yanmar is committed to maximising the safety of operators on site, so has equipped the SV100-2PB with a number of safety-critical features and technologies.

INTRICATE DESIGN

With a rigid ROPS, the SV100-2PB delivers unmatched stability and protection in the event of a roll-over. The cabin also conforms to FOPS I standard for protective structures against falling objects and can be equipped with an optional FOPS II guard.

24-HOUR OPERATION

Fitted as standard with three LED lights, positioned on the inner part of the boom and at the front of the cab, the SV100-2PB is perfect for use throughout the day and night. An additional LED headlight and beacon can be added to the rear of the cab, as an optional extra.

- + Safety lever to access the cab
- + Seat belt with retractor
- + Emergency engine stop
- + Anchor points for transport
- + Engine air cooling evacuation facing upwards
- + Evacuation hammer

SIMPLE MAINTENANCE

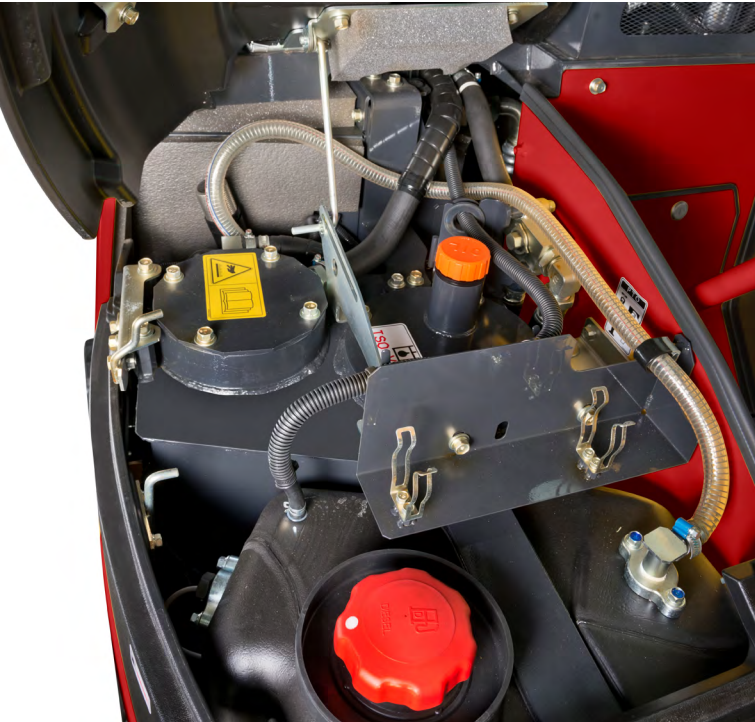

SIMPLE MAINTENANCE

The SV100-2PB integrates a number of features to minimise maintenance requirements. The corrugated radiator wall, for example, is designed to prevent crushing. The cab carpet is easy to clean and the air conditioning filter, located within the cab, can be easily removed for cleaning or replacement.

EASY ACCESS

The rear and side covers are large and easy to open – perfect for daily maintenance checks. Major components, alongside the hydraulic filter and air filter, are located under the back cover. The right covers provide access to the radiator, battery, fuel tank and hydraulic filling points, while the fan and air conditioner belts are easy to adjust.

Inside the cab, the panel beneath the seat and removable floor make it easy to access the relays, fuses and other components located underneath the cab.



LIFTING CAPACITY

 Tipping load, rating over front

 Tipping load, rating over side 90°

A: Overhang from rotational axis (m)

B: Height of hooking point (m)
C: Safe working load (kg)

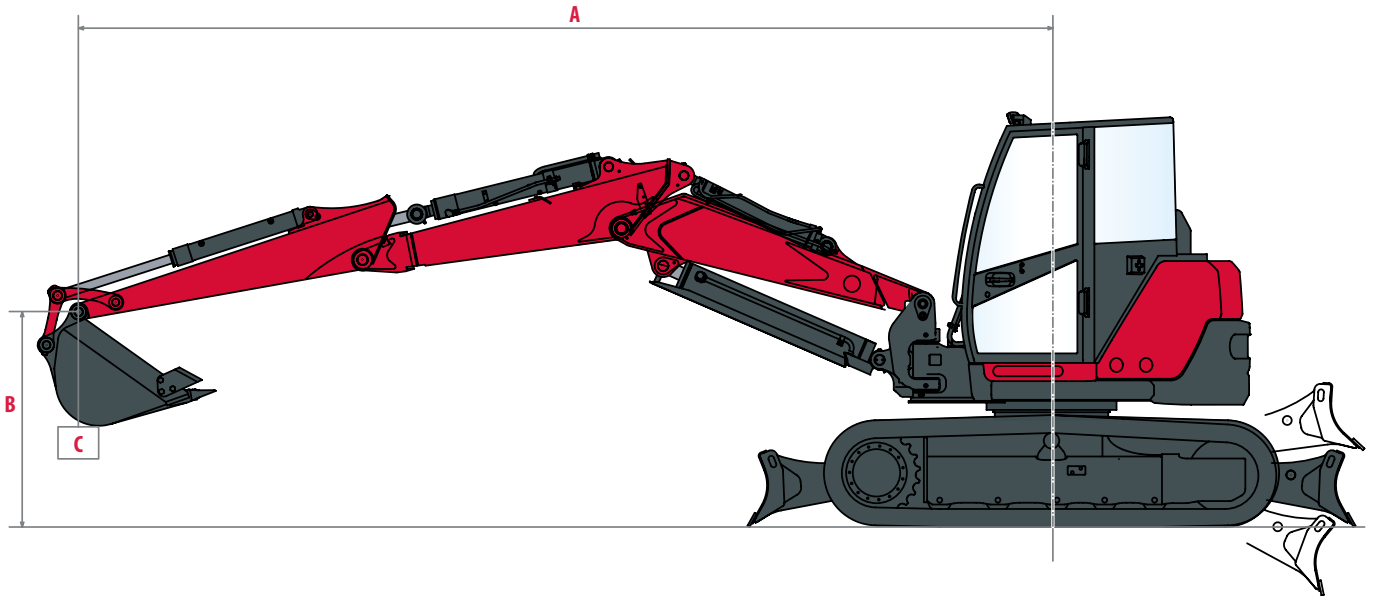

Short arm, additional counterweight

		Blade up									
A	Max.	6,0 m		5,0 m		4,0 m		3,0 m			
6,0 m	4 330	2 290*	2 730	--	--	--	--	2 740*	2 740	--	--
5,0 m	5 350	1 595*	2 260	--	--	1 800*	2 275	--	--	--	--
4,0 m	5 980	1 290*	2 035	--	--	1 760*	2 290*	2 625*	2 625	--	--
3,0 m	6 360	1 170*	1 900	1 305*	2 020	1 730*	2 350	2 480*	2 915	--	--
2,0 m	6 550	1 095*	1 780	1 240*	2 065	1 620*	2 530	2 190*	3 250	--	--
1,0 m	6 550	1 070*	1 655	1 210*	1 985	1 555*	2 550	2 050*	3 315	--	--
0,0 m	6 380	1 125*	1 515	1 200*	1 860	1 490*	2 410	1 975*	3 150	--	--
-1,0 m	6 010*	1 260*	1 260*	1 285*	1 285*	1 515*	2 120	2 010*	2 275*	3 305*	3 305
-2,0 m	5 390*	845*	845	--	--	1 390*	1 390*	1 960*	1 960*	2 250*	2 250

Short arm, additional counterweight

		Blade down									
A	Max.	6,0 m		5,0 m		4,0 m		3,0 m			
6,0 m	4 330	2 255*	2 730	--	--	--	--	2 740*	2 740	--	--
5,0 m	5 350	1 565	1 855	--	--	1 800*	2 275	--	--	--	--
4,0 m	5 980	1 285	1 515	--	--	1 770	1 920*	2 625*	2 625	--	--
3,0 m	6 360	1 145	1 350	1 295	1 500	1 700*	2 350	2 400*	2 915	--	--
2,0 m	6 550	1 090	1 290	1 235	1 490	1 610	1 970	2 180	2 670	--	--
1,0 m	6 550	1 060	1 265	1 210	1 425	1 550	1 845	2 025	2 470	--	--
0,0 m	6 380	1 100	1 340	1 195	1 400	1 490	1 795	1 980	2 420	--	--
-1,0 m	6 010*	1 260*	1 260*	1 285*	1 285	1 495	1 790	1 980*	2 775	2 850*	3 305
-2,0 m	5 390*	845*	845*	--	--	1 390*	1 390*	1 960*	1 960*	2 250*	2 250

[The data contained in these tables represent the lifting capacity in accordance with ISO standard 10567. They don't include the weight of the bucket and correspond to 75% of the maximum static tipping load or 87% of the hydraulic lifting power.]

DIMENSIONS

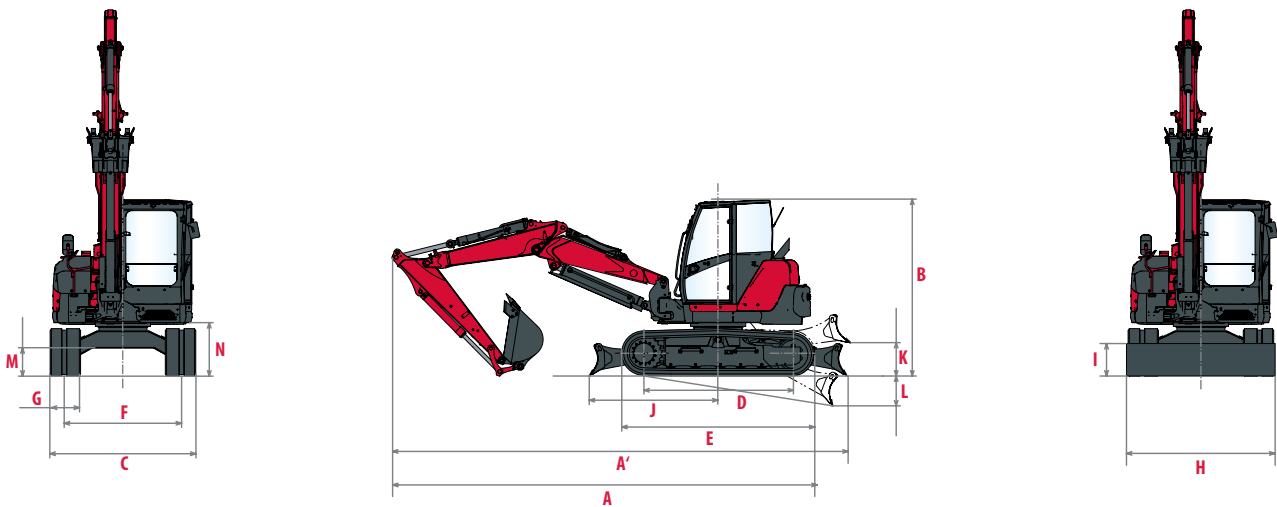

A Overall length	6 730 mm	H Overall blade width	2 320 mm
A' Overall length with blade at the back	7 230 mm	I Overall blade height	520 mm
B Overall height	2 840 mm	J Blade distance	2 040 mm
C Overall width	2 320 mm	K Max. lifting height above the ground	520 mm
D Length of track on ground	2 370 mm	L Max. lowering depth from the ground	460 mm
E Undercarriage length	3 070 mm	M Min. ground clearance	450 mm
F Lane	1 870 mm	N Min. ground clearance under counterweight	820 mm
G Track width	485 mm		

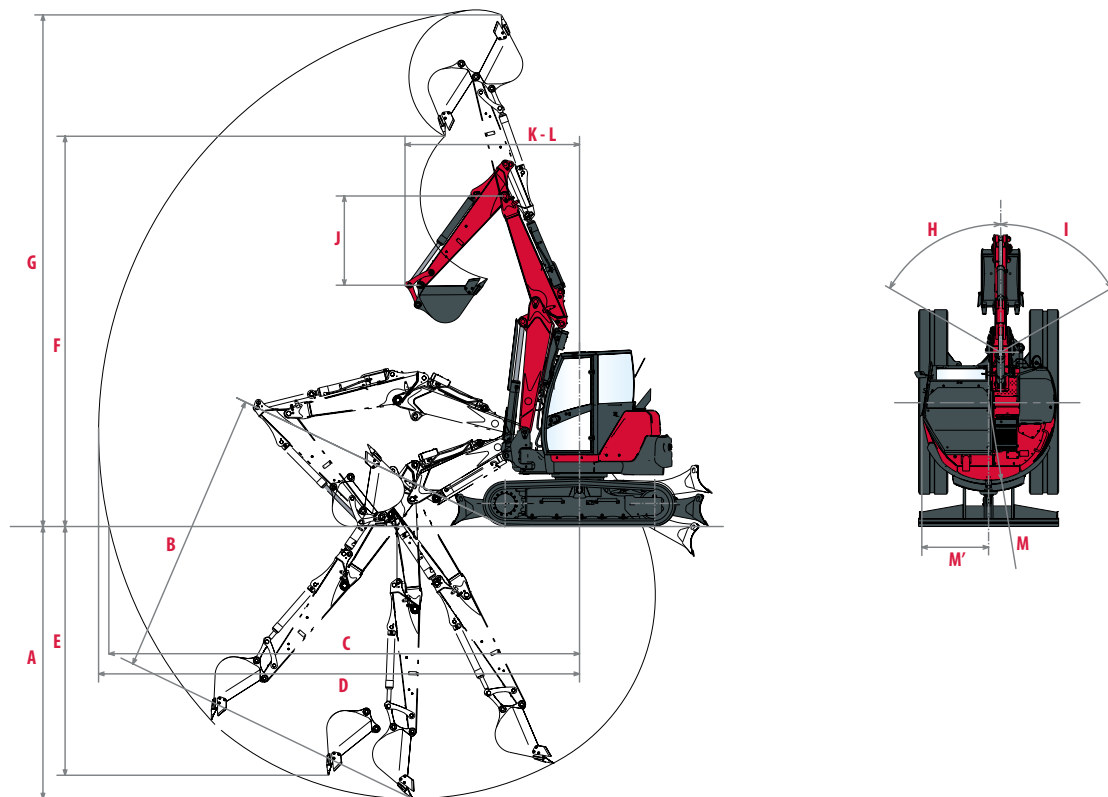

A Max. digging depth - Blade lifted	4 330 mm	H Boom swinging base to left	60°
B Max. digging depth - Blade lowered	4 580 mm	I Boom swinging base to right	60°
C Max. digging reach on ground	7 460 mm	J Arm length	1 950 mm
D Max. digging reach	7 640 mm	K Front turning radius	2 780 mm
E Max. vertical wall	3 960 mm	L Front turning radius with boom swing	2 640 mm
F Max. unloading height	6 210 mm	M Rear turning radius	1 330 mm
G Max. cutting height	8 220 mm	M' Rear turning radius with additional counterweight	1 470 mm

SPECIFICATIONS

[WEIGHT +/- 2% (EU-STANDARDS)]

	Transport weight	Operating weight	Ground pressure
With rubber tracks	10 285 kg	10 360 kg	0,410 kg/cm ²
With steel tracks (+ 50 kg)	10 335 kg	10 410 kg	0,420 kg/cm ²
With FOPS II protection (+ 100 kg - OPTION)	10 385 kg	10 460 kg	0,410 kg/cm ²

[ENGINE]

Type	4TNV98CT-VBV with DPF
Fuel	Diesel
Net power	51.7 kW (70.3 HP) at 2100 rpm
Gross power	53.7 kW (73 HP) at 2100 rpm
Displacement	3 318 cm ³
Maximum torque	283 Nm
Cooling	Water-cooling
Starter	3 kW
Battery	12 V – 115 Ah
Alternator	12 V – 80 A

[HYDRAULIC SYSTEM]

Maximum pressure	275 bar
1 piston pump with variable flow	2 x 77,7 l/min
1 gear pump	57,50 l/min
1 gear pump for pilot line	20 l/min

[AUXILIARY LINES]

PTO	Theoretical data at 2100 rpm		Oil flow decreases as the pressure increase.
	Pressure (bar)	Oil flow (l/min)	
1 way	0 – 245	130 – 60 l/min	
2 ways	0 – 245	130 – 60 l/min	

[PERFORMANCE]

Travel speed with steel tracks (low / high)	2.2 / 4.0 km/h
Travel speed with rubber crawler (low / high)	2.5 / 4.4 km/h
Rotation speed	9,1 rpm
Digging force (arm)	45,8 kN
Breakout force (bucket)	68,5 kN
Traction force	91,6 kN
Gradability	30°
Noise level (2000 / 14 / CE & 2005 / 88 / CE)	97 dBA / 72 dBA

[UNDERCARRIAGE]

Number of top rollers	1
Number of bottom rollers	5
Track tensioning system	Grease pump

[CAPACITIES]

Fuel tank	115 l
Coolant	10,6 l
Engine oil	11,2 l
Hydraulic circuit (including hydraulic tank)	115 l
Hydraulic tank	60 l

[MAINTENANCE FREQUENCY]

Change engine oil and filter: 250 hours | Change fuel filter: 500 hours | Change hydraulic oil filter: 1000 hours | Change hydraulic oil filter: 1000 hours | Change cooling fluid: 1000 hours | Clean particulate filter: 3000 hours | Change particle filter: 9000 hours.

EQUIPMENTS

[STANDARD EQUIPMENT]

PERFORMANCE

Diesel EU Stage V engine with Diesel Particulate Filter (DPF) | Direct Injection | Common Rail System | EGR Electrical Control System | Engine Control Unit (ECU) | Water Separator | Eco Mode | Auto-Idle System (auto deceleration) | Throttle using potentiometer | ViPPS Hydraulic system (ViO Progressive 3 Pump System) | 2 auxiliary circuits with adjustable proportional control by potentiometer | Electronic regulation of hydraulic pumps | Automatic 2nd speed | Filter on steering hydraulic circuit | External hydraulic oil gauge.

COMFORT & EASE OF USE

LCD interface | Cabin mounted on viscoelastic silent blocks | Air conditioning | Adjustable and reclining seat with fabric covers, air suspension and headrest | Adjustable wrist support | Foot rests | Wide travel pedals | Windshield with 2 fully retractable parts | Sliding double right side window | Transparent upper front part | Visor | Wipers | Windshield washer | Automatic ceiling lamp | Radio with USB port | 2 x 12V outlets | Storage Boxes | Secure document storage | Cup Holder.

SAFETY & DURABILITY

Handrails | Safety lever | Seat belt with retractor | Evacuation hammer | Anchor points | 5 mirrors | Horn | Travel beep | 1 LED light integrated into the boom | 2 LED lamps on the front of the cab | Asymmetric VICTAS tracks | 4 anchor points | Blade cylinder supply hose into two parts.

MISCELLANEOUS

2 Piece Boom | Additional counterweight | Electric refueling pump with automatic stop | Fuel gauge | Double axis position of the arm cylinder | Protection of the blade and boom cylinders | Hoses protected by abrasion-resistant sleeves | Cataphoresis treated steel parts | Locking Covers | Toolbox | Toolkit | Grease pump.

[OPTIONAL EQUIPMENT]

PERFORMANCE

Long arm | Safety valves for lifting + overload warning | Proportional 1st and 2nd hydraulic circuits lines to arm end | Grapple circuit | High pressure line for hydraulic quick coupler | Quick couplings.

COMFORT & EASE OF USE

Premium skai covered, adjustable and reclining seat with high backrest.

SAFETY & DURABILITY

Additional counterweight | Centralised greasing | Anti-theft (key/keyboard) | SmartAssist Remote | FOPS II protection grid.

MISCELLANEOUS

Special paint.

[ATTACHMENTS]

We offer a range of factory fitted attachments to maximize the versatility of your midi excavator. Yanmar offers selected mechanical and hydraulic quick couplers, powertilt, digging buckets, ditch cleaning buckets, rippers and breakers.



YANMAR



Yanmar Compact Equipment EMEA

GB_SV100-2PB_0921



www.yanmar.com

**TOGETHER
WE BUILD**

Printed in France – Materials and specifications are subject to change from the manufacturer without notice – Please contact your local Yanmar Compact Equipment EMEA dealer for further information.